



**EN**

## **Caravan water heater (CPVB-10)**

**TECHNICAL DESCRIPTION  
INSTALLATION, OPERATION AND MAINTENANCE  
INSTRUCTIONS  
WARRANTY CONDITIONS**

# Table of Contents

<b>EN</b>	
<b>Specifications</b>	<b>3</b>
<b>Option pages at a glance</b>	<b>4</b>
<b>Select operating mode</b>	<b>4</b>
<b>Assembly</b>	<b>5</b>
<b>Connection</b>	<b>6</b>
<b>Drainage</b>	<b>7</b>
<b>Further information</b>	<b>8</b>
General warnings .....	8
Safety instructions .....	8
Further important notes .....	8
Technical data .....	9
Assembly .....	9
Connection to the water supply .....	9
Electrical connection .....	11
Connection of an external AC Reheating .....	12
Operation .....	12
Maintenance .....	13
Malfunction .....	14
Environmental protection .....	14
Warranty .....	14





## **IMPORTANT!**

Please read these operating instructions carefully before installing and commissioning the hot water tank!

# Specifications

	UNIT	10 LITER
<b>PHOTOVOLTAIC WATER HEATER</b>		
Product model	-	CPVB-10
Volume	l	9,5
Rated pressures	MPa	0,7
IP-class	-	X1
Gross weight (± 3%)	Kg	8
Dimensions (length, width, height)	cm	44x33x30
Check and pressure relief valve	-	✓
Cathode protection	-	✓
Emailed protection	-	✓
Insulation	-	✓
Energy efficiency class		C
Water connection	-	G½ (M)
Integrated reverse polarity protection	-	✓
Digital display	-	✓
CE - certified	-	✓
<b>PHOTOVOLTAIC INPUT</b>		
Max. photovoltaic heating power	W	550
Max. photovoltaic current consumption	A	15,5
Max. water temperature	°C	65
Integrated MPP tracker	-	✓
Recommended photovoltaic power	W <sub>p</sub>	100 - 300
Max. connected photovoltaic power	W <sub>p</sub>	1.500
Max. open circuit voltage	V <sub>oc</sub>	42,4
Photovoltaic connector	-	MC4
<b>REHEATING VIA 230 V POWER GRID</b>		
Type of reheating		Power supply unit (12V, 18V or 24V)
Heating power	W	60 (12V), 160(18V) or 240(24V)
Adjustable water temperature range	°C	5 - 65
<b>HEATING VIA RECHARGEABLE BATTERY</b>		
Recommended technology		LFP, lead acid
Voltage level	V	12 or 24
<b>WATER HEATING DEPENDING ON THE CURRENTLY AVAILABLE PHOTOVOLTAIC POWER</b>		
200 W	°C/h	18
400 W	°C/h	36
550 W	°C/h	50

## Option pages at a glance

Nr	Information/Input option
1	Shows the water temperature in °C.
2	POWER IN: Shows the instantaneous power consumption of the boiler. VOLTAGE: Shows the current supply voltage of the boiler.
3	USED PV ENERGY: Displays the total PV energy consumed by the boiler.
4	CHANGE SYSTEM MODE: You can use the  - button to change the operating mode. <b>IMPORTANT!</b> Depending on which operating mode is active, option page nr. 5 differs.
5 (System Mode 1: Photovoltaic)	Reheat Temp: With the  - button you can change the photovoltaic reheat temperature via the power supply unit.
5 (System Mode 2: PV Battery)	Battery DCH Volt: With the  - button you can change the final discharge voltage of your battery. The system does not allow the voltage to fall below this value. <b>WARNING!</b> Do not undercut the <b>end of discharge voltage</b> of the battery, otherwise the battery could be <b>damaged</b> .
6	Change Maximum Temperature: With the  - button you can change the maximum temperature.
7	Shows the boiler type and the version number of the software.
8	Shows the hardware version number.

## Select operating mode

mode	description	primary energy source	secondary energy source
1: PV Home	The boiler is primarily powered by photovoltaic current. This mode should be selected if a PV module is connected or if there is an external energy management system (e.g. solar charge controller with deep discharge protection) that releases the current for the boiler.	PV module (Via MC4 Input)	Power supply (Via 4 pin external connector)
2: PV - Battery	Via the MC4 contact plugs, a battery can also be connected. As soon as the connected battery reaches a voltage of 13.5 V, the excess energy is used to power the boiler. This happens while the battery is being charged.	PV module (Via MC4 Input)	12 V or 24 V battery Approved: LiFePO4, lead acid battery (Via 4 pin external connector)

# Assembly

The caravan boiler must be mounted on a solid base plate with four screws. Use suitable screws or other mounting systems for your base plate.

1.

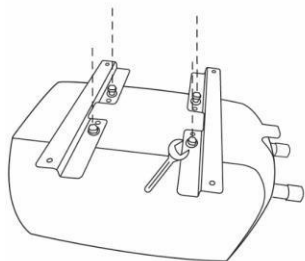

2.

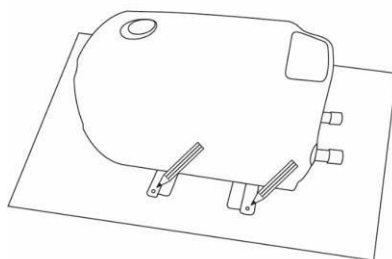

3.

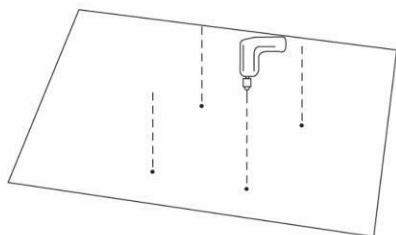

4.

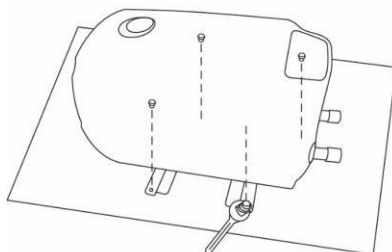

**IMPORTANT!** The Installation of the photovoltaic boiler is **only horizontally** possible.

# Connection

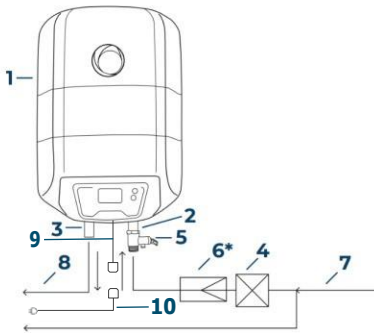

- 1 Water heater
  - 2 Water inlet
  - 3 Water outlet
  - 4 shut off valve\*
  - 5 combined check and - pressure relief valve
  - 6 Pressure reducing valve\*
  - 7 Cold water
  - 8 Hot water
  - 9 Device plug for external mains current
  - 10 Power cable\*
- \*not included

\*necessary if water pressure > 0,5 MPa (5 bar)

## heating time of the water depending on Power

Power	Value	CPVB-10
200 W	°C/h	6
400 W	°C/h	12
550 W	°C/h	16

**Note**

The values given in the table are intended as a guideline. The heating times depend on many factors (power, ambient air temperature, water withdrawal) and may differ from reality. The greater the connected photovoltaic power,

the more the water can be heated on days with low solar radiation. The water is heated with a maximum power of 550 W, even if more photovoltaic power is available.

# Drainage

The water in the boiler must not freeze. Frozen water in the boiler can cause damage or a defect of the appliance. If necessary, the contents of the boiler can be drained via the non-return/overpressure valve.

Proceed as follows:

- Ensure that any water that leaks from the non-return/overpressure valve can drain away safely. This is important to prevent possible water damage.
- Disconnect the water heater from any live electrical wiring.
- Shut off the cold-water supply.

- Open the hot water tap of the mixing tap or disconnect the hot water pipe (return pipe) of the water heater

- Tilt the small lever of the check/relief valve 90 °.

- The water should now drain away. The Drainage is complete when no more water comes out of the valves.

- Small amounts of water remain in the boiler even after emptying. This is fine and does not cause any damage

**WARNING!** The draining water can be hot - risk of scalding!

These steps do not ensure complete emptying of the water tank.

# Current source

**WARNING!** When connecting **several photovoltaic modules**, these must only be connected in **parallel**.

## Usable energy sources

Source	Voltage	Type
PV module	0-42,4 V <sub>oc</sub>	-
Battery	12 V, 24 V	Lead acid, LiFePO4
External energy management	12-42,4 V	-

**WARNING!** Connect the power supply only when the water heater is filled.

## Further information



Dear clients, thank you for choosing our device!

It will be a trustworthy helper in your household for many years because in its production we have combined high quality materials and innovative technologies. To be sure of its hopeful and trouble-free operation, please read the installation and operating instructions carefully.

**WARNING!** Before installation and operation with the appliance, read carefully the present manual!

### General warnings

Be sure to carefully read the instructions and warnings in this manual before installing and operating the water heater. The information contained in this manual is intended to familiarize you with the water heater, the rules of its correct and safe operation, and the minimum requirements for its maintenance and servicing. Furthermore, you are obliged to make this manual available to the qualified persons who will install and potentially repair the appliance. The installation of the water heater and the verification of its functionality is not within the distributor's warranty obligation nor the manufacturer.

These instructions should always be kept near the appliance for future reference. Compliance with the rules here described is part of the measures for the safe use of the product and is considered part of the warranty conditions.

### Safety instructions

**WARNING!** There is a risk of burns or scalding when using the appliance!

**WARNING!** This appliance may be used by children of age over 3 years old and persons with reduced physical, sensory or mental capabilities, or lack of experience and knowledge, where they are under supervision or instructed about the safe use of the appliance and understand the dangers. Children must not be allowed to play with the unit! It is absolutely forbidden that children undertake cleaning or servicing of this appliance! Children aged from 3 to 8 years are only allowed to operate the tap connected to the water heater.

**IMPORTANT!** Only qualified persons may install the water heater and connect it to the water pipe following the specifications given in this manual and the relevant local regulations. The protective devices provided or recommended by the manufacturer, as well as all other assemblies, are **UNCONDITIONALLY** to be installed!

**IMPORTANT!** Be sure to fill the water heater with water before connecting it to the electrical supply! Failure to comply with the electrical connection conditions affects the safety of the appliance, whereby the water heater must not be operated.

**IMPORTANT!** Observe the maximum permissible pressure (see chapter: Technical data).

### Further important notes

- The appliance is under pressure. During heating, expansion water may drip from the pressure relief valve.
- Operate the pressure relief valve regularly to prevent it from being stuck, e.g. due to limescale deposits.
- Install a type-tested pressure relief valve in the cold-water supply line. Note that depending on the pressure of the supply, you may also need a pressure reducing valve.
- Mount the pressure relief valve with the opening facing down.
- Mount the pressure relief valve and the drainpipe with a steady downward slope in a frost-free room.
- Dimension the drainpipe to allow the water to flow off unhindered when the pressure relief valve is fully open.
- The pressure relief valve opening must remain open to the atmosphere.



- This device contains a support battery, which is not replaceable. It is necessary for the display to function at night. A defect does not limit the basic functionality.
- This unit may be operated up to an altitude of 4000 m above sea level.
- Reheat Function is optional. You can either only use PV-energy or PV-energy combined with reheat-power.

## Technical data

This water heater can provide hot water from the mains water supply or other pressure-operated water supply for several consumers. The water used for heating must comply with the requirements in the normative documents for service water, in particular: Chloride content up to 250 mg/l; electrical conductivity more than 100 µS/cm, pH value 6,5-8 for enamelled hot water tanks. The thermal insulation consists of CFC-free polyurethane foam.

The maximum electrical power with PV-energy of the water heater is 550 W. The actual power consumption of the heating element depends on the connected photovoltaic power as well as on the radiation strength provided by the sun. The water is heated to a maximum of 65 °C to ensure scalding protection. Detailed information can be found in the data sheet or on the nameplate.

The water heater is equipped with a combined check and pressure relief valve (Table 1, No. 5) to prevent overpressure during appliance operation. The water tank is made of steel with a high-strength enamel coating and additional cathode protection provided by a magnesium anode.

## Assembly

Always install the water heater lying down, in a dry environment. The device is intended for fixed floor assembly. Make sure that the assembly surface is sufficiently stable to withstand forces that act on the boiler or its mounting system when driving.

When choosing a suitable substrate for the hot water storage tank, the following must be taken into account:

- Type and material
- Dimensions of the device,
- Type of fastening
- Location of fasteners for floor mounting
- Arrangement of water and electricity lines
- Degree of protection against water splashes

The installation site must comply with the requirements of the water and electrical installation. Sufficient space for the water connections must be provided during installation.

The boiler is bolted to the floor using the attached mounting rails. Four screws are used for this. The type, length and diameter of the screws must be selected according to the nature of the floor. Only with the right screws it is possible to safely install the boiler.

## Connection to the water supply

When connecting the device to the water supply, please observe the indicated arrows and rings around the cold and hot water pipes (supply and return pipes). The cold-water pipe features a blue ring and is marked with an arrow pointing towards the pipe. The hot water pipe is indicated by an arrow pointing out of the pipe and a red ring.

The water heater is equipped with a combined check and pressure relief valve, which is included in the product packaging and **MUST** be installed on the cold-water pipe. The arrow on the body of the valve, which indicates the direction of water flow through the valve, must be followed during this installation.

**WARNING!** The absence or improper installation of the combined valve supplied with the product is grounds for voiding the product warranty.

**WARNING!** It is **FORBIDDEN** to install any kind of shut-off fittings between the combined valve and the water heater! It is absolutely forbidden to obstruct the lateral opening of the combined valve and/or to block its lever!

The pipe connectors have male G½ threads.

The water heater operates by the pressure of the water pipe. The water pressure of the water supply system should be higher than 0.1 MPa (1 bar) and lower than 0.5 MPa (5 bar). If the pressure of the water pipe exceeds 0.5 MPa, a pressure reducing valve must be installed.

If additional equipment, which is not included in the standard delivery, must be used to comply with local regulations, they must be installed according to these specifications.

In case the water pipes are made of copper or other metal which differs from the metal of the water tank, as well as if connecting elements made of brass are used, non-metal fittings must be installed on the supply and return side of the water heater (dielectric fittings).

**WARNING!** The installation of any shut-off or non-return fittings between the pressure relief valve and the water heater, as well as blocking the side opening of the pressure relief valve and/or locking its lever is prohibited!

A drainage system to remove any water that may drip from the side opening of the pressure relief valve is recommended. The drain line must be designed with a constant downward slope in a frost-free environment and must remain open.

After connecting the water heater to the water supply, fill the tank with water. The sequence of steps to be performed is:

- Fully open the hot water tap at the furthest point of use.
- Open the shut-off valve. (Table 1, No. 4)
- Wait until the air is released from the system and a strong jet of water flows from the mixer tap. Let the water run for about 30 seconds.
- Close the hot water tap at the extraction point.
- Lift the small lever of the pressure relief valve (Table 1, No. 5), wait 30-60 seconds until a strong stream of water flows out of the side opening of the valve.
- Loosen the valve lever.

**WARNING!** If no water or only a thin stream of water flows out of the valve opening, this indicates a malfunction. A possible contamination of the water pipe might be present. The fault must be eliminated before the unit is put into operation.

**It is FORBIDDEN** to proceed with appliance electric connection before eliminating the reason for malfunction!

**WARNING!** Failure to comply with the requirements for connection to the water supply system may cause partial filling up of the water tank and malfunction of the heating element, or when the combined valve is not installed at all or has been improperly installed. This may even cause destruction of the water tank, the room and/or other damages to tangible and intangible property. Such consequences are not within the scope of manufacturer or seller warranty liabilities and shall be at the expense of the party, which has not observed the present manual instructions.

**WARNING!** The combined check and pressure relief valve is one of the protective devices that ensure the safe operation of the water heater. The use of the water heater with a damaged or removed/unassembled combined check and pressure relief valve (safety valve) is **STRICTLY PROHIBITED!**

The pressure relief valve can also be used to drain the water from the tank if desired. In such case, proceed as follows:

- Disconnect the water heater from any live electrical wiring.
- Disconnect the cold-water inlet.
- Open the hot water tap of the mixing tap or disconnect the hot water pipe (return pipe) of the water heater.
- Lift the small lever of the pressure relief valve (Table 1, No. 5) and wait until no more water leaves the valve.
- **WARNING!** The running water can be hot – risk of scalding.

These steps do not still secure the complete draining of the water out of the tank. It is completed only by a qualified person because it requires complete disconnection of the appliance electric circuit and dismantling the water tank flange.

**WARNING!** It is **STRICTLY PROHIBITED** to turn on the heater power while the water tank is partially or completely emptied of water! Do not forget to fill the tank with water before putting it back into operation.

**WARNING!** The coolant circulation through the heat exchanger of a water heater equipped with such device is **PROHIBITED** when the water tank is partially or completely emptied of water.

**WARNING!** When draining the water out of the water tank all necessary precautions must be taken to prevent damages from flowing out water.

**IMPORTANT!** In Denmark, Sweden, Norway and Finland, the connection of the water heater to the public water supply may only be performed using a suitable pressure reducing valve. The local regulations must be observed.

## Electrical connection

**WARNING!** Any electrical connection may only be performed when the water heater is filled with water.

**IMPORTANT!** The water heater is powered by direct current. The water heater is protected against electric shock "class III" and may only be supplied with safety extra-low voltage (SELV). Only power sources recommended by the manufacturer may be connected. A faulty and/or unsuitable power supply involves a high risk and is likely to cause an accident. The connection cables of the device must be replaced if they are damaged.

**IMPORTANT!** Photovoltaic modules may **ONLY** be connected in **parallel**. When connecting more than one photovoltaic module, always use a suitable connector for parallel connection. For more information, refer to the illustration "Parallel PV-Connector". Connecting photovoltaic modules in series will damage the water heater.

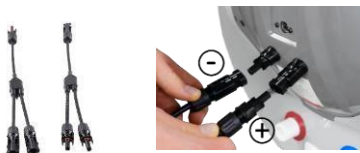

Parallel PV-Connector

Pay attention to correct polarity when connecting!

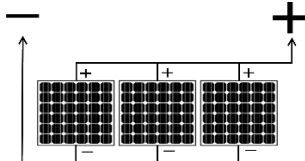

Connection of PV-modules in parallel configuration only!  
Serial connection will damage the unit!

The electrical connection of the water heaters is performed using MC4 plugs. Check the functionality of the appliance after the electrical connection has been performed. When all supply connections are removed, the water heater is completely disconnected from the power sources.

### CONNECTION OF PV-MODULES:

**IMPORTANT!** The installation and electrical parallel connection of PV modules may only be carried out by a qualified person and may not endanger third parties. When installing the photovoltaic modules, the locally prevailing rules and laws must be complied with.

**IMPORTANT!** Keep cables out of the way to avoid tripping over them or getting caught. There is a risk of injury. The cables must be fastened in such a way that no tensile load is applied to the connectors. Furthermore, it must be ruled out that the cables and connectors rub against surfaces and edges (e.g. in wind). The cables must not lie in water permanently.

**IMPORTANT!** Only photovoltaic modules with a maximum of 60 resp. 120 cells and an open-circuit voltage of 42.4 V may be connected.

- Photovoltaic modules must be connected correctly using the factory supplied MC4 plugs.
- You may connect up to five modules in parallel. Depending on the module, this corresponds to an MPP output of approximately 1500 W<sub>p</sub>.

Dimensioning of the required photovoltaic power:

- The higher the number of hours of sunshine per day, the smaller the required PV power.
- The warmer the water taken from the pipeline, the lower the required PV power.
- Dimension the required photovoltaic power according to the months with the lowest solar radiation in which the photovoltaic water heater will be in operation.
- The greater the amount of hot water consumed per day, the larger the PV power required.

The following table serves as a guideline for dimensioning the photovoltaic power needed depending on the climatic conditions:

Climatic conditions	CPVB-10
Countries with low sunshine e.g. Northern and Central Europe	300 W <sub>p</sub>
Sunny countries e.g. Southern Europe and Africa	150 W <sub>p</sub>

*These values given are guidelines. Depending on the conditions prevailing on site and the specific conditions of consumption, the appropriate design of the photovoltaic output may vary from the values described.*

### Extension of the photovoltaic line:

When extending the photovoltaic cable, the MC4 contact plugs must be properly attached to ensure functionality and safety. Basically, the PV cable should be kept as short as possible.

A length recommendation depending on the connected nominal PV generator power can be found in the following table.

Connected PV-Power	4 mm <sup>2</sup>	6 mm <sup>2</sup>
~325 W <sub>p</sub>	≤ 18 m	≤ 27 m
~650 W <sub>p</sub>	≤ 11 m	≤ 16 m
~975 W <sub>p</sub>	≤ 9 m	≤ 13 m

*Recommended cable length (there and back) for different nominal powers and cross-sections*

## Connection of an external AC Reheating:

**IMPORTANT!** Only use certified connection plugs (IEC-320 - C13 plugs) recommended by the manufacturer. Non-compliance will invalidate the warranty and may damage the water heater. The external reheating feature extended use of the photovoltaic boilers. For example, long periods of bad weather can be bridged by connected AC power.

## Operation

**WARNING!** This appliance may be used by children of age over 3 years old and persons with reduced physical, sensory or mental capabilities, or lack of experience and knowledge, where they are under supervision or instructed about the safe use of the appliance and understand the dangers. Children must not be allowed to play with the unit! It is absolutely forbidden that children undertake cleaning or servicing of this appliance! Children aged from 3 to 8

years are only allowed to operate the tap connected to the water heater.

### Operation:

#### Switch On:

Press the -  button for three seconds.

#### Display:

The present water temperature is shown on the display.

- POWER IN: Input power of the PV modules
- VOLTAGE: Input voltage of the PV modules
- USED PV ENERGY: Total PV energy utilised

#### Menu Navigation:

Press the -  button briefly. By pressing the button again, you jump to the next page in the menu.

#### Settings:

Press the -  button repeatedly. This allows individual adjustments on the unit to be made. Please note: The adjustments are only active when an external energy supply is connected to the photovoltaic water heater.

- **CHANGE SYSTEM MODE:** Select the desired mode by pressing the  - button. Mode 1 (PV HOME) is set as the factory default.

### Quick guide: System modes

#### Mode 1: Photovoltaic

For the direct connection of photovoltaic modules. If desired plus AC-reheating via mains current.

#### Mode 2: PV Battery

For the connection of other energy sources such as a battery. A battery cable is needed to plug in the battery via MC4-connectors. The battery is not included. More detailed information can be found in the respective product description.

**WARNING!** When setting the battery DCH Voltage (discharge voltage), it is important to consider the **voltage loss** in the cables connecting the water heater with the battery.

#### Switch off:

Press the  - button for three seconds.

## Further important notes:

### Leakage of water

The pressure relief valve can drip during the operation of the water heater due to the expansion of the water while heating. Ensure that the leaking water is directed to a collection container or a drain. The dripping of water does not indicate a defect. The side valve opening must not be closed under any circumstances.

The installation of a drainpipe facilitates future maintenance and servicing operations, as the water can be drained from the water heater easily.

### Noise emission

Noise may be generated inside the device during the heating process, which is caused by lime deposits on the heating element. An increased formation of limescale can be observed at water temperatures above 60°C. This may cause impairment and damage to the heating elements and the water heater.

### Formation of legionella

Due to the small volume of the hot water tanks, the risk of the formation of legionella in the system is almost excluded. Nevertheless, to take precautions, the following measures are recommended:

- Supply of fresh water or regular water withdrawal.
- Heating the water frequently to at least 60 °C.
- It is recommended to change the water after the appliance has not been used for more than one month.

## Maintenance

**IMPORTANT!** Before maintenance and servicing, disconnect the boiler from the mains and other energy sources.

**IMPORTANT!** The cover may only be opened by qualified personnel.

### Repair instructions

All electronic repair work may only be carried out by a qualified electronic technician. There is a risk of injury. Modifying the cables and electronics voids the warranty. The cables of the circuit (DC) of the solar modules are marked red and black.

## Corrosion protection

Every water heater features an enamelled water tank with additional corrosion protection. This corrosion protection consists of a magnesium anode (sacrificial anode). The anode is a wearing part (i.e. it wears out during normal operation of the unit). The average life span is about 3 years, which depends particularly on the operating mode of the appliance as well as the characteristics of the water to be heated. The condition of the anode should be checked at regular intervals and, if necessary, replaced by a service specialist authorized by the manufacturer or distributor.

Compliance with the deadline and the timely renewal of the anode are important conditions for efficient corrosion protection of the water tank. The examination and the renewal of the anode are not included in the warranty obligations of the manufacturer nor the dealer. To ensure the safe operation of the water heater in regions with calcareous water, it is recommended to clean the water tank regularly from accumulated limestone. Such cleaning should be carried out at least every two years, or more frequently in regions with calcareous water. Deposits on the enamel coating do not need to be scraped off, just wiped off with a dry cotton cloth. The regular cleaning and removal of the limescale is essential to ensure the safe operation of the appliance. Whilst cleaning the anode of the enamelled water tank should also be checked. These services are not part of the warranty scope and must be carried out by qualified persons. The regulations for the inspection of the anode protection and renewal of the anode, as well as the removal of the collected limestone, must be observed both during and after the expiration of the warranty period for the appliance.

### Combined check and pressure relief valve

To guarantee the proper and safe operation of the water heater, regularly check the combined check and pressure relief valve for reduced permeability. For this purpose, lift the small lever and wait approx. 30-60 seconds until a strong stream of water flows out of the valve opening on the side. This check must be carried out after filling the tank with water, at 2-week intervals and after failure and restoration of the water supply. If no water or only a thin stream flows out of the valve opening, this indicates a malfunction. A possible contamination of the water pipe might be present. The fault must be eliminated before commissioning.

## Cleaning

The outer casing and the plastic parts of the water heater should only be cleaned with a lightly moistened cotton cloth, free of aggressive and/or scouring agents. Do not clean the appliance with a steam cleaner. The water heater may only be put back into operation after the moisture has completely vanished.

## Malfunction

In case of a malfunction during the operation of the water heater, disconnect all live wires from the appliance and contact the manufacturer or your distributor.

## Environmental protection

This device is labelled by the Waste Electrical and Electronic Equipment (WEEE) directive. By ensuring that the appliance is taken to a suitable disposal centre at the end of its service life, you will help to protect the environment and prevent negative effects on the environment and human health. The -symbol on the water heater indicates that the appliance must not be disposed of with regular household waste at the end of its life. The product must be taken to a disposal centre with special facilities for electrical or electronic equipment. The end-user must comply with local disposal regulations when disposing of the product.

For more information on treatment, recovery, and recycling procedures, contact your local city office, your local waste disposal centre, or the retailer from whom you purchased the product.

## Warranty

The warranty of the appliance is only valid under the following conditions:

- The unit is installed in accordance with the installation and operating instructions.
- The appliance is only used for its intended purpose and in accordance with the installation and operating instructions.

The manufacturer's warranty covers the repair of all manufacturing defects that occur during the warranty period. Only professionals authorized by the seller may carry out repairs. The warranty does not cover damage resulting from:

- Improper transport
- improper storage
- improper use
- unsuitable water parameters
- improper electrical voltage which deviates from the rated voltage
- freezing of water
- exceptional risks, accidents, or other force majeure
- failure by disregarding the installation and use instructions
- in all cases when an unauthorized person attempts to repair the appliance.

In the aforementioned cases, the damage will be repaired against payment. The guarantee does not apply to parts and components of the device that are worn out during its normal operation, nor to parts that are dismantled, to lights and signal lamps, etc., to discoloration of external surfaces, to changes in the shape, dimensions, and arrangement of parts and components that have been subjected to an impact that does not correspond to the normal conditions of use of the device. Any missed benefits, material and immaterial damages resulting from temporary inability to use the unit during the period of its repair and maintenance, are not covered by the warranty of the unit.

COMPLIANCE WITH THE REQUIREMENTS SPECIFIED IN THE MANUAL IS A PREREQUISITE FOR THE SAFE OPERATION OF THE PURCHASED PRODUCT AND IS INCLUDED IN THE TERMS OF THE WARRANTY. ANY MODIFICATIONS OR ALTERATIONS TO THE DESIGN OF THE PRODUCT MADE BY THE USER OR PERSONS AUTHORISED BY THE USER ARE STRICTLY PROHIBITED. ANY SUCH ACTS OR ATTEMPTS SHALL VOID THE WARRANTY OBLIGATIONS OF THE MANUFACTURER OR DISTRIBUTOR. THE MANUFACTURER RESERVES THE RIGHT TO MAKE STRUCTURAL CHANGES WITHOUT NOTICE, PROVIDED THAT THE SAFETY OF THE PRODUCT IS NOT AFFECTED. WHEN NECESSARY, OR IN CASE OF MISUNDERSTANDINGS IN CONNECTION REGARDING THE TRANSLATION OR TERMS USED IN THIS LANGUAGE VERSION OF THE INSTALLATION AND OPERATING INSTRUCTIONS, PLEASE USE THE GERMAN VERSION AS THE ORIGINAL AND PRIMARY VERSION.