



EN

Photovoltaic water heater (PVHB-200 / PVHB-300)

TECHNICAL DESCRIPTION
INSTALLATION, OPERATION AND MAINTENANCE
INSTRUCTIONS
WARRANTY CONDITIONS

Table of Contents

EN

Schematics	3
Specifications	4
LED-Display	6
Connection	7
Further information	8
General warnings.....	8
Safety instructions	8
Further important notes.....	8
Technical data.....	9
Assembly.....	9
Connection to the water supply	9
Electrical Connection.....	11
Maintenance.....	13
Malfunction.....	13
Environmental protection.....	13
Warranty.....	13

IMPORTANT!

Please read these operating instructions carefully before installing and commissioning the hot water tank!

Schematics

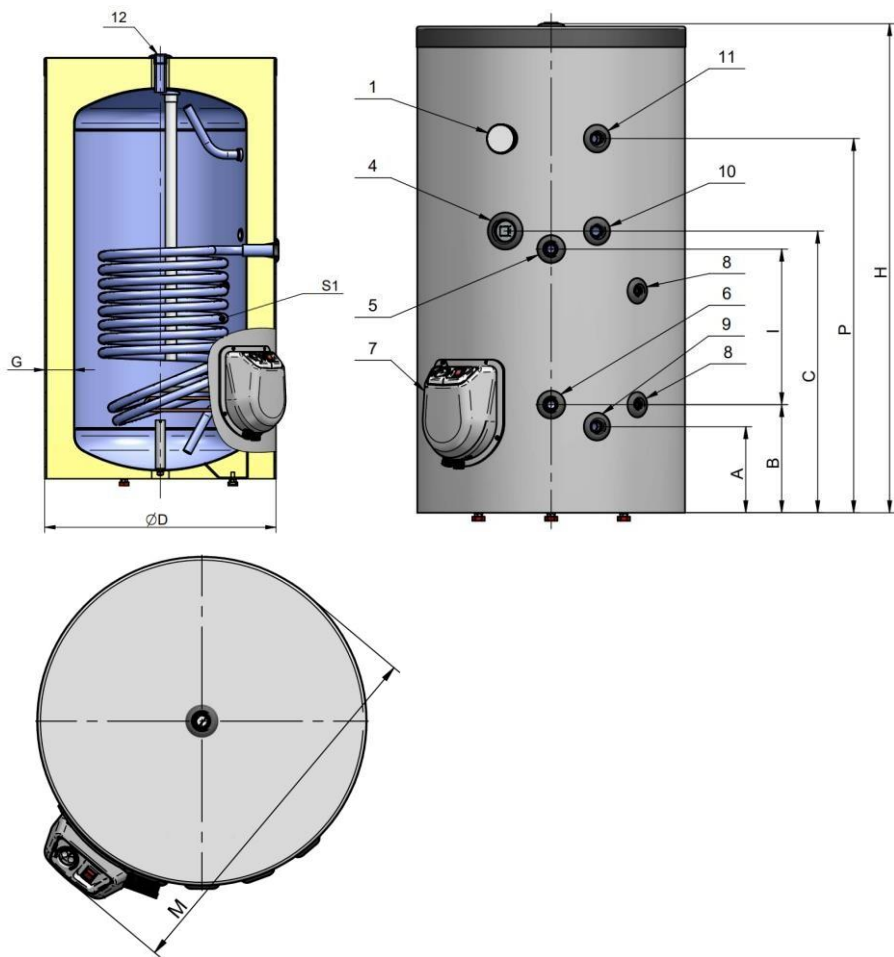

Specifications

	UNIT	200 LITER	300 LITER
PHOTOVOLTAIC WATER HEATER			
Product model	-	PVHB-200	PVHB-300
Volume group	-	200	300
Standing loss heat	W	47,5	50,2
Rated pressure	MPa	0,8	0,8
Volume	l	186	264
Gross weight (± 3 %)	kg	74	86
LED Status Indication	-	✓	✓
Time of heating with photovoltaic power at a sunny day (1500W heating power) from 10°C up to 65°C	h	7½	10¾
Max. photovoltaic heating temperature	°C	65°C	65°C
Usable thermal capacity (heating from 10°C to 65°C)	kWh	11,9	16,8
MPP tracker quantity	-	3	3
Reverse polarity protection	-	✓	✓
Boiler made of steel with enamel coating	-	✓	✓
Combined check and pressure relief valve	-	✓	✓

PHOTOVOLTAIC INPUT

Max. photovoltaic heating power	W	1.650	1.650
Max. photovoltaic heating power per MPP tracker	W	550	550
Max. connected photovoltaic power	W _p	4.500	4.500
Max. connected photovoltaic power per MPP tracker	W _p	1.500	1.500
Recommended photovoltaic setup	W _p	1800-3600	2200-4000
Max. open circuit voltage *[1]	V _{oc}	55	55
MPPT voltage range	V	25-42	25-42

CONNECTIONS

1: Thermometer	-	✓	✓
4: Additional socket (for example AC reheat from grid)	-	G 1½ F	G 1½ F
5: Heat exchanger S1 - Feed	-	G ¾ F	G ¾ F
6: Heat exchanger S1 - Return	-	G ¾ F	G ¾ F
7: Photovoltaic connection	-	Screw Terminal	Screw Terminal
8: Socket for thermostat	-	G 1½ F	G 1½ F
9: Fresh water inlet - Drain	-	G ¾ F	G ¾ F
10: Recirculation	-	G ¾ F	G ¾ F
11 / 12: Hot water outlet	-	G ¾ F	G ¾ F

HEAT EXCHANGER S1

Operating pressure	MPa	1,0	1,0
Max. temperature of the heating fluid	°C	110	110
Max. Temperature in the tank heated by the heat exchanger	°C	95	95
Surface area	m ²	0,90	1,12

Volume	l	4,3	5,4
NL *[2]	-	3,6	8,0
Continuous output according DIN 4708	kW	25	35
Flow rate according DIN 4708	l/min	10	14
Power according EN 12897	kW	18,6	19,3
Heat up time according EN 12897	min	28,8	39,4
Pressure loss	mbar	120	50
Maximum amount of drained water mix 40°C according EN 12897 when the power is off	l	286	406

DIMENSIONS

A	mm	210	210
B	mm	260	265
C	mm	855	840
D	mm	600	670
G	mm	75	85
H	mm	1430	1605
I	mm	550	530
M	mm	690	760
P	mm	1155	1315

Notes:

All values in the table are approximate

*[1] To ensure the open circuit voltage stays below the max value, please connect photovoltaic module(s) in parallel strings to each MPP-tracker. This value is the maximum input voltage rating of one MPP tracker. Please take the temperature coefficient of the photovoltaic module into consideration.

*[2] The declared values of the NL coefficient are determined according to DIN 4708 under the following conditions:

- Water temperature entering inlet pipe of the appliance heat exchanger - 80 °C.
- Cold water temperature entering the appliance - 10 °C.
- Water heating temperature in the appliance - 60 °C.

The heat-up time with the electric resistance heater is for actual capacity.

Transformation of the coefficient of performance at different water temperatures in the tank:

- 65 °C – 1,0*NL
- 55 °C – 0,75*NL
- 50 °C – 0,55*NL
- 45 °C – 0,3*N

LED-Display

The three Independently operating MPP-trackers all have a Status LED for indication.

Colour	Description	Heating Power
Off	No heating - the maximum water temperature has been reached (65°C) or the system is switched off with the switch or photovoltaic input too weak.	-
White	Heating up - the system works in regular MPPT mode.	7W - 100 W
Magenta	Heating up - the system works in regular MPPT mode.	100 W – 300 W
Green	Heating up - the system works in regular MPPT mode.	300 W – 500 W
Blue	Heating up - the system works in regular MPPT mode.	Above 500 W
Yellow flashing	Heating with reduced current - The system heats without MPP-tracking due to excess photovoltaic power or risk of overheating	Up to 600W
Red	Error- Safety temperature limiter has tripped*	-
Red slowly flashing	Error - Heater rod not connected correctly or defective*	-
Red fast flashing	Error - System does not heat because electronics is overheated. This state is automatically exited after 5 minutes*	-

*Contact customer service if the error is permanently displayed.

Connection

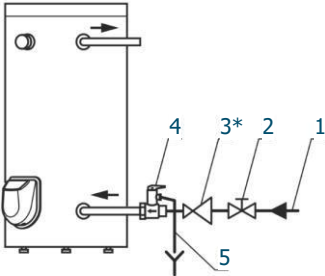

- 1 Water supply mains outlet
- 2 Shut off valve*
- 3 Pressure reducing valve*
- 4 Combined valve
- 5 Pipe diverting water from the combined valve safety valve*

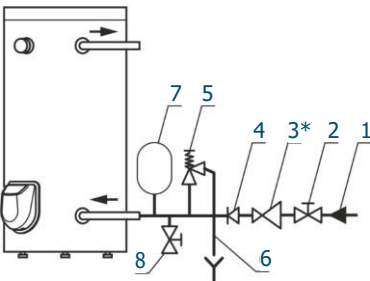

- 1 Water supply mains outlet
- 2 Shut off valve*
- 3 Pressure reducing valve*
- 4 Back flow stop* (non-return valve)
- 5 Safety valve
- 6 Pipe diverting water from the combined valve safety valve*
- 7 Expansion vessel*
- 8 Drain valve*

*not included

*for water pressure in the mains above 0,5 MPa

Heating time of the water depending on Heating-Power

Total Heating Power	PVHB-200	PVHB-300
600 W	3 °C/h	2 °C/h
1200 W	5.5 °C/h	4 °C/h
1650 W	7°C/h	5 °C/h

Note The values given in the table are intended as a guideline. The heating times depend on many factors (power, ambient air temperature, water withdrawal) and may differ from reality. The greater the connected photovoltaic power, the more the water

can be heated on days with low solar radiation. The water is heated with a maximum power of 1650W, even if more photovoltaic power is available.

Further information



Dear clients, thank you for choosing our device!

It will be a trustworthy helper in your household for many years because in its production we have combined high quality materials and innovative technologies. To be sure of its hopeful and trouble-free operation, please read the installation and operating instructions carefully.

WARNING! Before installation and operation with the appliance, read carefully the present manual!

General warnings

Be sure to carefully read the instructions and warnings in this manual before installing and operating the water heater. The information contained in this manual is intended to familiarize you with the water heater, the rules of its correct and safe operation, and the minimum requirements for its maintenance and servicing. Furthermore, you are obliged to make this manual available to the qualified persons who will install and potentially repair the appliance. The installation of the water heater and the verification of its functionality is not within the distributor's warranty obligation nor the manufacturer.

These instructions should always be kept near the appliance for future reference. Compliance with the rules here described is part of the measures for the safe use of the product and is considered part of the warranty conditions.

Safety instructions

WARNING! There is a risk of burns or scalding when using the appliance!

WARNING! This appliance may be used by children of age over 3 years old and persons with reduced physical, sensory or mental capabilities, or lack of experience and knowledge, where they are under supervision or instructed about the safe use of the appliance and understand the dangers. Children must not be allowed to play with the unit! It is absolutely forbidden that children undertake cleaning or servicing of this appliance! Children aged from 3 to 8 years are only allowed to operate the tap connected to the water heater.

IMPORTANT! Only qualified persons may install the water heater and connect it to the water pipe following the specifications given in this manual and the relevant local regulations. The protective devices provided or recommended by the manufacturer, as well as all other assemblies, are **UNCONDITIONALLY** to be installed!

IMPORTANT! Be sure to fill the water heater with water before connecting it to the electrical supply! Failure to comply with the electrical connection conditions affects the safety of the appliance, whereby the water heater must not be operated.

IMPORTANT! Observe the maximum permissible pressure (see chapter: Technical data).

Further important notes

- The appliance is under pressure. During heating, expansion water may drip from the pressure relief valve.
- Operate the pressure relief valve regularly to prevent it from being stuck, e.g. due to limescale deposits.
- Install a type-tested pressure relief valve in the cold-water supply line. Note that depending on the pressure of the supply, you may also need a pressure reducing valve.
- Mount the pressure relief valve with the opening facing down.
- Mount the pressure relief valve and the drainpipe with a steady downward slope in a frost-free room.
- Dimension the drainpipe to allow the water to flow off unhindered when the pressure relief valve is fully open.
- The pressure relief valve opening must remain open to the atmosphere.

- This unit may be operated up to an altitude of 4000 m above sea level.

Technical data

This water heater can provide hot water from the public water supply system for several consumers. The water used for heating must comply with the requirements in the normative documents for domestic water, in particular: Chloride content up to 250 mg/l; electrical conductivity more than 100 µS/cm, pH value 6,5-8 for enameled hot water tanks. The thermal insulation consists of CFC-free polyurethane foam.

The **maximum heating power** with PV-energy of the water heater is **1650 W**. The actual heating power of the heating elements depends on the connected photovoltaic power as well as on the irradiation strength provided by the sun. The water is heated to a **maximum of 65 °C** to ensure scalding protection. Detailed information can be found in the data sheet or on the nameplate.

The water heaters are equipped with a combined check and pressure relief valve to prevent overpressure during appliance operation. The water tanks are made of steel with a high-strength enamel coating and additional cathode protection provided by a magnesium anode.

Assembly

The water heater can be installed only in normal fire safeguarded premises and where temperature cannot fall below 0 °C. The availability of a siphon on the installation for waste waters as during normal usage of the water heater, water may leak from the safety valve aperture. At the same time the siphon will facilitate the water tank maintenance, prevention and servicing operations when water needs to be drained out of the water tank.

When selecting a suitable installation location for the water heater, the following must be considered:

- dimensions of the unit,
- installation type,
- arrangement of the pipes and the degree of protection against water leakage,
- load capacity of the floor.

The appliance must be placed where it is protected against water dispersion or water pouring over. In order to reduce heat loss it is recommended to keep

minimum distance between the heater and the places where the hot water is used. The location of the device must comply with the requirements for the electric installation and its contact. It is obligatory that there are spaces provided between the appliance and the surrounding walls.

At least 70 mm between the appliance and the ceiling; at least 50 mm between the appliance and the side wall.

The installation site must comply with the requirements of the electrical installation. During installation, provide sufficient distance to adjacent walls and sufficient space under the unit for the water and photovoltaic connections.

Connection to the water supply

According to the connection drawing and the explanations in the specifications, observe the correct connection of the hot water pipe (connection 11/12) and the cold water pipe (connection 9).

The water heater is equipped with a combined check and pressure relief valve, which is included in the product packaging and **MUST** be installed on the cold-water pipe. The arrow on the body of the valve, which indicates the direction of water flow through the valve, must be followed during this installation.

WARNING! It is **FORBIDDEN** to install any kind of shut-off fittings between the combined valve and the water heater! It is absolutely forbidden to obstruct the lateral opening of the combined valve and/or to block its lever!

The pipe connectors have male G $\frac{3}{4}$ threads.

The water heater operates by the pressure of the water pipe. The water pressure of the water supply system should be higher than 0.1 MPa (1 bar) and lower than 0.5 MPa (5 bar). If the pressure of the water pipe exceeds 0.5 MPa, a pressure reducing valve must be installed.

If additional equipment, which is not included in the standard delivery, must be used to comply with local regulations, they must be installed according to these specifications. In case the water pipes are made of copper or other metal which differs from the metal of the water tank, as well as if connecting elements made of brass are used, non-metal fittings must be installed on the supply and return side of the water heater (dielectric fittings).

WARNING! The installation of any shut-off or non-return fittings between the pressure relief valve and the water heater, as well as blocking the side opening of the pressure relief valve and/or locking its lever is prohibited!

A drainage system to remove any water that may drip from the side opening of the pressure relief valve is recommended. The drain line must be designed with a constant downward slope in a frost-free environment and must remain open.

After connecting the water heater to the water supply, fill the tank with water. The sequence of steps to be performed is:

- Fully open the hot water tap of the most distant mixing tap.
- Open the shut-off valve
- Wait until the air is released from the system and a strong jet of water flows from the mixer tap. Let the water run for about 30 seconds.
- Close the hot water tap of the mixer tap.
- Lift the small lever of the pressure relief valve, wait 30-60 seconds until a strong stream of water flows out of the side opening of the valve.
- Loosen the valve lever.

WARNING! If no water or only a thin stream of water flows out of the valve opening, this indicates a malfunction. The fault must be eliminated before the unit is put into operation.

It is **FORBIDDEN** to proceed with appliance electric connection before eliminating the reason for malfunction!

WARNING! Failure to comply with the requirements for connection to the water supply system may cause partial filling up of the water tank and malfunction of the heating element, or when the combined valve is not installed at all or has been improperly installed this may even cause destruction of the water tank, the room and/or other damages to tangible and intangible property. Such consequences are not within the scope of manufacturer or seller warranty liabilities and shall be at the expense of the party, which has not observed the present manual instructions.

WARNING! The combined check and pressure relief valve is one of the protective devices that ensure the safe operation of the water heater. The use of the water heater with a damaged or

removed/unassembled combined check and pressure relief valve (safety valve) is **STRICTLY PROHIBITED!**

The pressure relief valve can also be used to drain the water from the tank if desired. In such case, proceed as follows:

- Disconnect the water heater from any live electrical wiring.
- Disconnect the cold-water inlet.
- Open the hot water tap of the mixing tap or disconnect the hot water pipe (return pipe) of the water heater.
- Lift the small lever of the pressure relief valve and wait until no more water leaves the valve.
- **Warning!** The running water can be hot – risk of scalding.

These steps do not still secure the complete draining of the water out of the tank. It is completed only by a qualified person because it requires complete disconnection of the appliance electric circuit and dismantling the water tank flange.

WARNING! It is **PROHIBITED** to turn on the heater power while the water tank is partially or completely emptied of water! Do not forget to fill the tank with water before putting it back into operation.

WARNING! The coolant circulation through the heat exchanger of a water heater equipped with such device is **PROHIBITED** when the water tank is partially or completely emptied of water.

WARNING! When draining the water out of the water tank all necessary precautions must be taken to prevent damages from flowing out water.

IMPORTANT! In Denmark, Sweden, Norway and Finland, the connection of the water heater to the public water supply may only be performed using a suitable pressure reducing valve. The local regulations must be observed.

Electrical Connection

WARNING! Any electrical connection may only be performed when the water heater is filled with water.

IMPORTANT! At the Photovoltaic input of the MPP trackers (PV1-, PV1+ / PV2-, PV2+ / PV3-, PV3+), the water heater is powered by direct current directly from photovoltaic modules. The water heater is protected against electric shock "class III" and may only be supplied with safety extra-low voltage (SELV). Only power sources recommended by the manufacturer may be connected.

IMPORTANT! High voltage photovoltaic modules (60/120cell / 72/144cell modules) may be connected in **parallel**. When connecting more than one photovoltaic module to one MPP-tracker, always use a suitable connector for parallel connection.

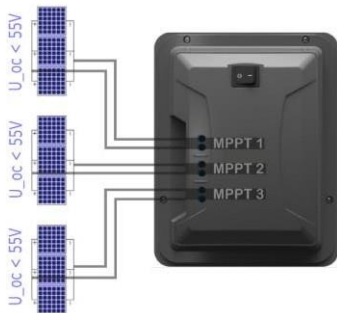

Connection of an example system (3x 300W 60 cell Module per MPP tracker, total 2700Wp)

The photovoltaic module(s) should be connected to the screw terminals of the MPP-trackers of the water heater with 4mm² - 10mm² cables and with the use of ferrules. Tighten the connection with a Phillips screwdriver to a torque of 1.2 Nm and check the contact for mechanical strength. When all supply connections are removed, the water heater is completely disconnected from the power sources.

CONNECTION OF PV-MODULES:

IMPORTANT! The installation and electrical parallel connection of PV modules may only be carried out by a qualified person and may not endanger third parties. When installing the photovoltaic modules, the

locally prevailing rules and laws must be complied with.

IMPORTANT! Keep cables out of the way to avoid tripping over them or getting caught. There is a risk of injury. The cables must be fastened in such a way that no tensile load is applied to the connectors. Furthermore, it must be ruled out that the cables and connectors rub against surfaces and edges (e.g. in wind). The cables must not lie in water permanently.

IMPORTANT! Only photovoltaic modules with a **maximum** of 72 resp. 144 cells and an **open-circuit voltage of 55 V** may be connected.

- Photovoltaic modules are connected to each other via factory supplied MC4 connectors.
- You may connect more than one module in parallel. Depending on the module, you have to connect x modules in parallel to each MPP-tracker to get the desired / recommended total photovoltaic power.

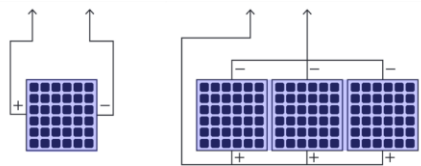

Parallel connection of x photovoltaic modules for reference

Dimensioning of the required photovoltaic power:

- The higher the number of hours of sunshine per day, the smaller the required PV power.
- The warmer the water taken from the pipeline, the lower the required PV power.
- Dimension the required photovoltaic power according to the months with the lowest solar radiation in which the water heater will be in operation.
- The greater the amount of hot water consumed per day, the larger the PV power required.

IMPORTANT NOTE! The photovoltaic module numbers/ size / model do not necessarily have to match between the three independent MPP-trackers. They only have to be equal in parallel connected string of x modules per MPP-tracker.

Recommended photovoltaic Setup:

The following table serves as a guideline for dimensioning the photovoltaic power needed depending on the climatic conditions. For high demand of hot water, it is recommended to choose the higher value.

Climatic conditions	PVHB-200	PVHB-300
Countries with low sunshine e.g. Northern and Central Europe	1800-3600 W _p	2200-4000 W _p
Sunny countries e.g. Southern Europe and Africa	1200-1800 W _p	1200-2400 W _p

These values given are recommendations. Depending on the conditions prevailing on site and the specific conditions of consumption, the appropriate design of the photovoltaic output may vary from the values described.

Operation

WARNING! This appliance may be used by children of age over 3 years old and persons with reduced physical, sensory or mental capabilities, or lack of experience and knowledge, where they are under supervision or instructed about the safe use of the appliance and understand the dangers. Children must not be allowed to play with the unit! It is absolutely forbidden that children undertake cleaning or servicing of this appliance! Children aged from 3 to 8 years are only allowed to operate the tap connected to the water heater.

Usage:

Switch On:

Flip the switch button on top of the housing to the on position ("I"-symbol).

The system will power up, if at least one MPP-tracker is connected to PV-power.

Switch Off:

Flip the switch button on top of the housing to the off position ("O"-symbol).

Further important notes:

Leakage of water

The pressure relief valve can drip during the operation of the water heater due to the expansion of the water while heating. Ensure that the leaking water is directed to a collection container or a drain. The dripping of water does not indicate a defect. The side valve opening must not be closed under any circumstances.

The installation of a drainpipe facilitates future maintenance and servicing operations, as the water can be drained from the water heater easily.

Noise emission

Noise may be generated inside the device during the heating process, which is caused by lime deposits on the heating element. An increased formation of limescale can be observed at water temperatures above 60°C.

Formation of legionella

Due to the small volume of the hot water tanks, the risk of the formation of legionella in the system is almost excluded. Nevertheless, to take precautions, the following measures are recommended:

- Supply of fresh water or regular water withdrawal.
- Heating the water frequently to at least 60 °C.
- It is recommended to rinse the tank after the appliance has not been used for more than one month.

Maintenance

IMPORTANT! Before maintenance and servicing, disconnect the boiler from the mains and other energy sources.

IMPORTANT! The cover may only be opened by qualified personnel.

Repair instructions

All electronic repair work may only be carried out by a qualified electronic technician. There is a risk of injury. Modifying the cables and electronics voids the warranty.

Combined check and pressure relief valve

To guarantee the proper and safe operation of the water heater, regularly check the combined check and pressure relief valve for reduced permeability. For this purpose, lift the small lever and wait approx. 30-60 seconds until a strong stream of water flows out of the valve opening on the side. This check must be carried out after filling the tank with water, at 2-week intervals and after failure and restoration of the water supply. If no water or only a thin stream flows out of the valve opening, this indicates a malfunction. A possible contamination of the water pipe might be present. The fault must be eliminated before commissioning.

Cleaning

The outer casing and the plastic parts of the water heater should only be cleaned with a lightly moistened cotton cloth, free of aggressive and/or scouring agents. Do not clean the appliance with a steam cleaner. The water heater may only be put back into operation after the moisture has completely vanished.

Malfunction

In case of a malfunction during the operation of the water heater (signalized by red LED or malfunction in useage), disconnect all live wires from the appliance and contact the manufacturer or your distributor.

Environmental protection

This device is labelled by the Waste Electrical and Electronic Equipment (WEEE) directive. By ensuring that the appliance is taken to a suitable disposal centre at the end of its service life, you will help to protect the environment and prevent negative effects on the environment and human health. The  - symbol on the water heater indicates that the appliance must not be disposed of with regular household waste at the end of its life. The product must be taken to a disposal centre with special facilities for electrical or electronic equipment. The end-user must comply with local disposal regulations when disposing of the product. For more information on treatment, recovery, and recycling procedures, contact your local city office, your local waste disposal centre, or the retailer from whom you purchased the product.

Warranty

The warranty of the appliance is only valid under the following conditions:

- The unit is installed in accordance with the installation and operating instructions.
- The appliance is only used for its intended purpose and in accordance with the installation and operating instructions.

The manufacturer's warranty covers the repair of all manufacturing defects that occur during the warranty period. Only professionals authorized by the seller may carry out repairs. The warranty does not cover damage resulting from:

- Improper transport
- improper storage
- improper use
- unsuitable water parameters
- improper electrical voltage which deviates from the rated voltage
- freezing of water

- exceptional risks, accidents, or other force majeure
- failure by disregarding the installation and use instructions
- in all cases when an unauthorized person attempts to repair the appliance.

In the aforementioned cases, the damage will be repaired against payment. The guarantee does not apply to parts and components of the device that are worn out during its normal operation, nor to parts that are dismantled, to lights and signal lamps, etc., to discoloration of external surfaces, to changes in the shape, dimensions, and arrangement of parts and components that have been subjected to an impact that does not correspond to the normal conditions of use of the device. Any missed benefits, material and immaterial damages resulting from temporary inability to use the unit during the period of its repair and maintenance, are not covered by the warranty of the unit.

COMPLIANCE WITH THE REQUIREMENTS SPECIFIED IN THE MANUAL IS A PREREQUISITE FOR THE SAFE OPERATION OF THE PURCHASED PRODUCT AND IS INCLUDED IN THE TERMS OF THE WARRANTY. ANY MODIFICATIONS OR ALTERATIONS TO THE DESIGN OF THE PRODUCT MADE BY THE USER OR PERSONS AUTHORISED BY THE USER ARE STRICTLY PROHIBITED. ANY SUCH ACTS OR ATTEMPTS SHALL VOID THE WARRANTY OBLIGATIONS OF THE MANUFACTURER OR DISTRIBUTOR. THE MANUFACTURER RESERVES THE RIGHT TO MAKE STRUCTURAL CHANGES WITHOUT NOTICE, PROVIDED THAT THE SAFETY OF THE PRODUCT IS NOT AFFECTED. WHEN NECESSARY, OR IN CASE OF MISUNDERSTANDINGS IN CONNECTION REGARDING THE TRANSLATION OR TERMS USED IN THIS LANGUAGE VERSION OF THE INSTALLATION AND OPERATING INSTRUCTIONS, PLEASE USE THE GERMAN VERSION AS THE ORIGINAL AND PRIMARY VERSION.